

Joint estimation of bipartite network collections. Application to plant-pollinator networks.

Rochebrune 2026

Louis Lacoste, Pierre Barbillon and Sophie Donnet
UMR MIA Paris-Saclay, AgroParisTech, INRAE, Université Paris-Saclay



15 Juillet 2025

Why a network?

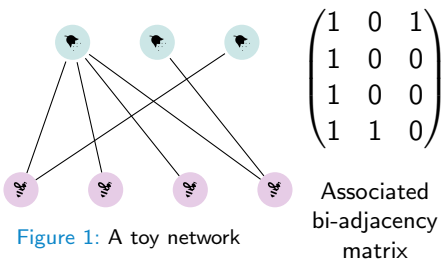

- Bipartite graph
 $G = (U, V, E)$
- Encoded in bi-adjacency matrix $Y \in \{0, 1\}^{n_1 \times n_2}$

Why a network?

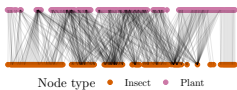

Figure 1: Plant-pollinator network from Bristol
Baldock et al., 2019

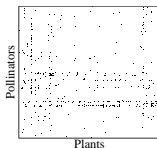

Figure 2: Adjacency matrix of the network

- Increasingly available
- Ecosystems described by their interactions
- Functional structure for: biodiversity monitoring, robustness, risk of collapse

Analysis methods for a network

Several methods :

- Metrics at
 - ▶ node level: degree, centrality. . .
 - ▶ network level: density, nestedness. . .

Kolaczyk, 2009

- Node embedding and/or clustering with latent variable models
Snijders and Nowicki, 1997; Hoff et al., 2002
- Node or network embedding with Graph Convolutional Networks
Kipf and Welling, 2016

Analysis methods for a network

Several methods :

- Metrics at
 - ▶ node level: degree, centrality. . .
 - ▶ network level: density, nestedness. . .

Kolaczyk, 2009

- **Node embedding and/or clustering with latent variable models**
Snijders and Nowicki, 1997; Hoff et al., 2002
- Node or network embedding with Graph Convolutional Networks
Kipf and Welling, 2016

Bipartite Stochastic Block Model (BiSBM¹)

Govaert and Nadif, 2005

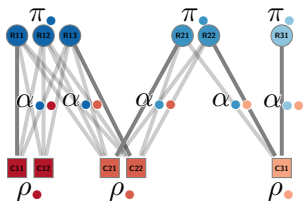

Figure 3: Example of BiSBM

Hierarchical model

$$\forall q \in \llbracket 1, Q_1 \rrbracket, \mathbb{P}(Z_i = q) = \pi_q$$

$$\forall r \in \llbracket 1, Q_2 \rrbracket, \mathbb{P}(W_j = r) = \rho_r$$

$$Y_{ij} | Z_i = q, W_j = r \sim \text{Bern}(\alpha_{q,r})$$

where

$$|\pi| = Q_1, |\rho| = Q_2, |\alpha| = Q_1 \times Q_2$$

Concise BiSBM formula

$$Y \sim \text{Bern-BiSBM}_{n_1, n_2}(Q_1, Q_2, \pi, \rho, \alpha)$$

¹Commonly Known as *Latent Block Model* (LBM) in the literature.

How to compare multiple networks?

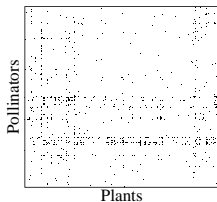

(a) Bristol

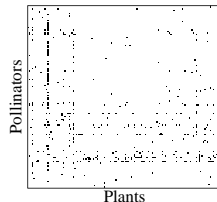

(b) Edinburgh

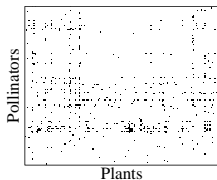

(c) Leeds

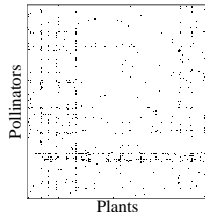

(d) Reading

Figure 4: Adjacency matrices, Baldock et al., 2019

First approach: sep-BiSBM

$$\forall m \in \{1 \dots M\}, Y^m \stackrel{ind}{\sim} \text{Bern-BiSBM}_{n_1^m, n_2^m}(Q_1^m, Q_2^m, \pi^m, \rho^m, \alpha^m)$$

First approach: sep-BiSBM

$$\forall m \in \{1 \dots M\}, Y^m \stackrel{ind}{\sim} \text{Bern-BiSBM}_{n_1^m, n_2^m}(Q_1^m, Q_2^m, \pi^m, \rho^m, \alpha^m)$$

First approach: sep-BiSBM

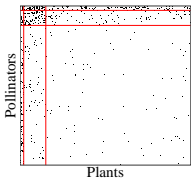

(a) Bristol, $Q_1 = 3, Q_2 = 3$

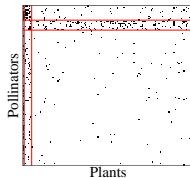

(b) Edinburgh, $Q_1 = 3, Q_2 = 3$

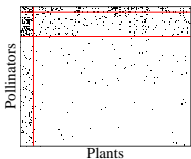

(c) Leeds, $Q_1 = 3, Q_2 = 2$

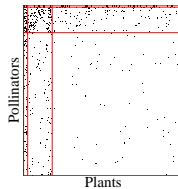

(d) Reading, $Q_1 = 3, Q_2 = 3$

Figure 5: Separate BiSBM fit for each network

Our contribution: joint models

iid-colBiSBM

$$\forall m \in \{1 \dots M\}, Y^m \stackrel{iid}{\sim} \text{Bern-BiSBM}_{n_1^m, n_2^m}(Q_1, Q_2, \pi, \rho, \alpha)$$

with $\theta = (\pi, \rho, \alpha)$.

- No shared nodes across networks
- Agnostic of structure

Our contribution: joint models

iid-colBiSBM

$$\forall m \in \{1 \dots M\}, Y^m \stackrel{iid}{\sim} \text{Bern-BiSBM}_{n_1^m, n_2^m}(Q_1, Q_2, \pi, \rho, \alpha)$$

with $\theta = (\pi, \rho, \alpha)$.

$\pi\rho$ -colBiSBM

$$\forall m \in \{1 \dots M\}, Y^m \stackrel{ind}{\sim} \text{Bern-BiSBM}_{n_1^m, n_2^m}(Q_1, Q_2, \pi^m, \rho^m, \alpha)$$

with $\theta = ((\pi^m)_{m=1, \dots, M}, (\rho^m)_{m=1, \dots, M}, \alpha)$.

- No shared nodes across networks
- Agnostic of structure

Parameter estimation

How ?

$$\begin{aligned}\ell(\mathbf{Y}; \theta) &= \sum_{m=1}^M \ell(Y^m; \theta) \\ &= \sum_{m=1}^M \log \sum_{Z^m \in \mathcal{Z}^m, W^m \in \mathcal{W}^m} \exp\{\ell_c(Y^m, Z^m, W^m; \theta)\} \\ &= \sum_{m=1}^M \log \sum_{Z^m \in \mathcal{Z}^m, W^m \in \mathcal{W}^m} \exp\{\ell(Y^m | Z^m, W^m; \alpha) + \\ &\quad \ell(Z^m; \pi) + \ell(W^m; \rho)\}\end{aligned}$$

Parameter estimation

How ?

$$\begin{aligned}\ell(\mathbf{Y}; \theta) &= \sum_{m=1}^M \ell(Y^m; \theta) \\ &= \sum_{m=1}^M \log \sum_{\mathbf{Z}^m \in \mathcal{Z}^m, \mathbf{W}^m \in \mathcal{W}^m} \exp\{\ell_c(Y^m, \mathbf{Z}^m, \mathbf{W}^m; \theta)\} \\ &= \sum_{m=1}^M \log \sum_{\mathbf{Z}^m \in \mathcal{Z}^m, \mathbf{W}^m \in \mathcal{W}^m} \exp\{\ell(Y^m | \mathbf{Z}^m, \mathbf{W}^m; \alpha) + \\ &\quad \ell(\mathbf{Z}^m; \pi) + \ell(\mathbf{W}^m; \rho)\}\end{aligned}$$

EM impracticable since $\mathbf{Z}, \mathbf{W} | \mathbf{Y}$ intractable due to conditional dependency.

Parameter estimation

Solution

Variational EM Daudin et al., 2008; Chabert-Liddell et al., 2024.

Variational approximation of $\mathbf{Z}, \mathbf{W} | \mathbf{Y}$

$\mathcal{R}_{Y^m, \tau}(Z^m, W^m) = \mathcal{R}_{Y^m, \tau}^1(Z^m) \times \mathcal{R}_{Y^m, \tau}^2(W^m) \Rightarrow$ independence between rows and columns, mean field approximation.

$$\ell(\mathbf{Y}; \theta) \geq \sum_{m=1}^M \left(\mathbb{E}_{\mathcal{R}_{Y^m, \tau}(Z^m, W^m)} [\ell_c(Y^m, Z^m, W^m; \theta)] + \mathcal{H}(\mathcal{R}_{Y^m, \tau}(Z^m, W^m)) \right) =: \mathcal{J}(\mathcal{R}_{\mathbf{Y}, \tau}; \theta)$$

where $\theta = (\pi, \rho, \alpha)$ for *iid-colBiSBM*

Selection criterion for Q_1, Q_2

Integrated Classification Likelihood (ICL) [Biernacki et al., 2000](#)

$$\begin{aligned} \text{ICL}(\mathbf{Y}, Q_1, Q_2) &= \mathbb{E}_{\mathbf{Z}, \mathbf{W} | \mathbf{Y}}[\ell_c(\mathbf{Y}, \mathbf{Z}, \mathbf{W}; \hat{\theta})] - \frac{1}{2} \text{pen}(Q_1, Q_2) \\ &= \ell(\mathbf{Y}; \hat{\theta}) - \mathcal{H}(p(\mathbf{Z}, \mathbf{W} | \mathbf{Y}; \hat{\theta})) - \frac{1}{2} \text{pen}(Q_1, Q_2) \end{aligned}$$

For SBM [Daudin et al., 2008](#).

Selection criterion for Q_1, Q_2

Integrated Classification Likelihood (ICL) [Biernacki et al., 2000](#)

$$\begin{aligned}\text{ICL}(\mathbf{Y}, Q_1, Q_2) &= \mathbb{E}_{\mathbf{Z}, \mathbf{W} | \mathbf{Y}}[\ell_c(\mathbf{Y}, \mathbf{Z}, \mathbf{W}; \hat{\theta})] - \frac{1}{2} \text{pen}(Q_1, Q_2) \\ &= \ell(\mathbf{Y}; \hat{\theta}) - \mathcal{H}(p(\mathbf{Z}, \mathbf{W} | \mathbf{Y}; \hat{\theta})) - \frac{1}{2} \text{pen}(Q_1, Q_2)\end{aligned}$$

For SBM [Daudin et al., 2008](#).

$$\begin{aligned}\text{BIC-L}(\mathbf{Y}, Q_1, Q_2) &= \mathbb{E}_{\mathcal{R}_{\mathbf{Y}, \hat{\tau}}}[\ell_c(\mathbf{Y}, \mathbf{Z}, \mathbf{W}; \hat{\theta}^{\text{var}})] + \mathcal{H}(\mathcal{R}_{\mathbf{Y}, \hat{\tau}}) - \frac{1}{2} \text{pen}(Q_1, Q_2) \\ &= \mathcal{J}(\mathcal{R}_{\mathbf{Y}, \hat{\tau}}, \hat{\theta}^{\text{var}}) - \frac{1}{2} \text{pen}(Q_1, Q_2)\end{aligned}$$

Results Baldock et al., 2019

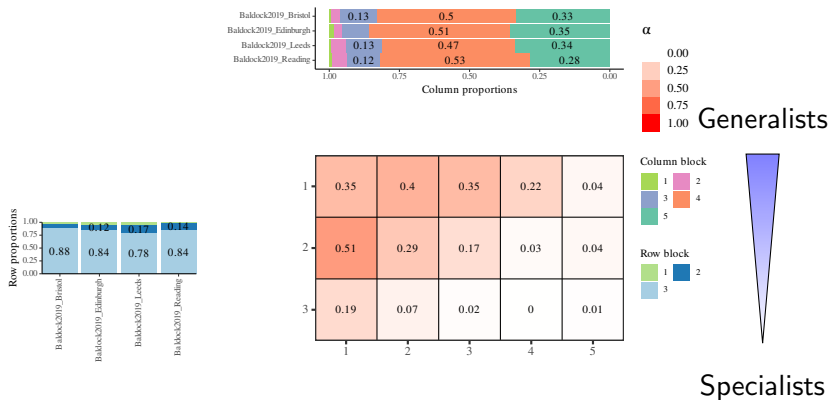
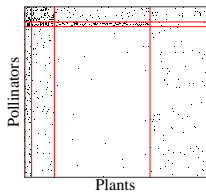
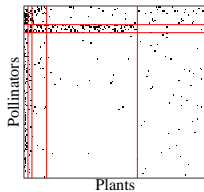

Figure 6: Shared structure (α matrix) and proportions (π and ρ) of the four networks

Results Baldock et al., 2019



(a) Bristol



(b) Edinburgh

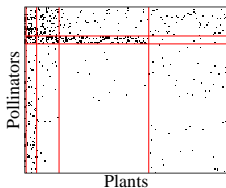

(c) Leeds

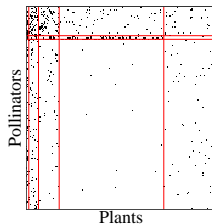

(d) Reading

Figure 6: *iid*-colBiSBM fit, $Q_1 = 3$, $Q_2 = 5$

Focus on Leeds

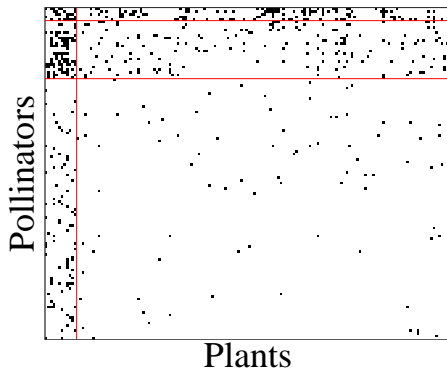

(a) *sep-BiSBM*, $Q_1 = 3$, $Q_2 = 2$

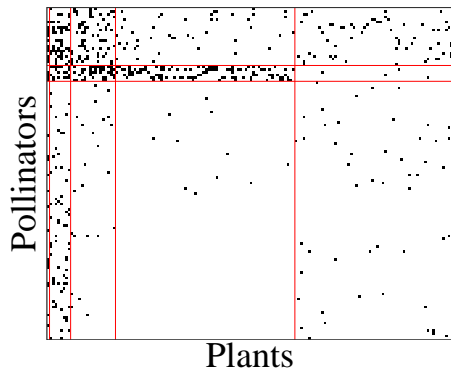

(b) *iid-colBiSBM*, $Q_1 = 3$, $Q_2 = 5$

Bombus



(a) *Bombus hortorum* or garden bumblebee



(b) *Bombus lapidarius* or red-tailed bumblebee

Bombus



(a) *Bombus hortorum* or garden bumblebee

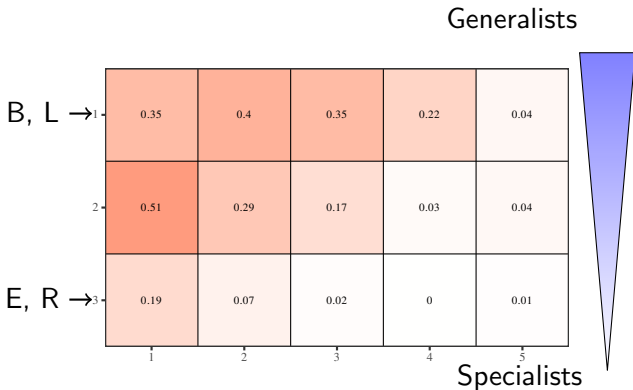

Figure 9: Shared structure (α matrix) of the four networks

Bombus



(b) *Bombus Lapidarius* or red-tailed bumblebee

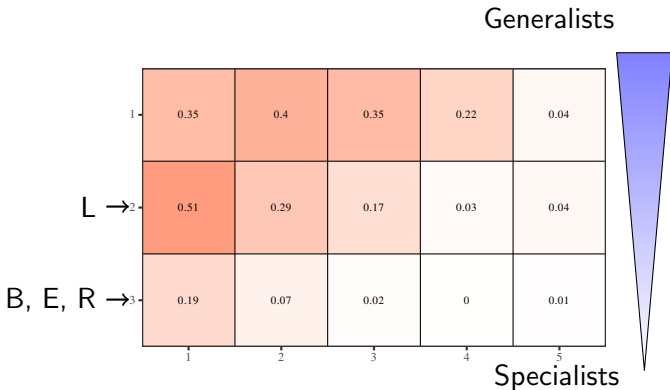



Figure 9: Shared structure (α matrix) of the four networks

Conclusion and perspectives

Summary

- Joint and agnostic structure detection.
- Partitioning algorithm for collections.
- R package `colSBM`  `GrossSBM/colSBM`.
- An article under review.

Future work: phylogenetic tree and Latent Position Model

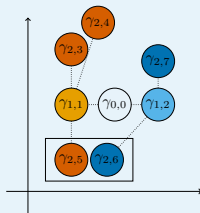
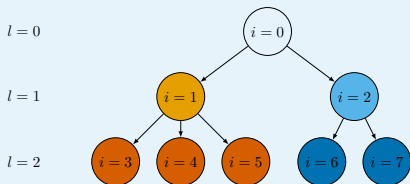

Pu et al., 2025; Wilms and Bien, 2022

References I

- Baldock, K. C. R., Goddard, M. A., Hicks, D. M., Kunin, W. E., Mitschunas, N., Morse, H., Osgathorpe, L. M., Potts, S. G., Robertson, K. M., Scott, A. V., Staniczenko, P. P. A., Stone, G. N., Vaughan, I. P., & Memmott, J. (2019). A systems approach reveals urban pollinator hotspots and conservation opportunities. *Nature Ecology & Evolution*, 3(3), 363–373.
<https://doi.org/10.1038/s41559-018-0769-y>
- Kolaczyk, E. D. (2009). *Statistical Analysis of Network Data: Methods and Models*. Springer New York.
<https://doi.org/10.1007/978-0-387-88146-1>
- Snijders, T. A., & Nowicki, K. (1997). Estimation and Prediction for Stochastic Blockmodels for Graphs with Latent Block Structure. *Journal of Classification*, 14(1), 75–100.
<https://doi.org/10.1007/s003579900004>

References II

- Hoff, P. D., Raftery, A. E., & Handcock, M. S. (2002). Latent Space Approaches to Social Network Analysis. *Journal of the American Statistical Association*, 97(460), 1090–1098.
<https://doi.org/10.1198/016214502388618906>
- Kipf, T. N., & Welling, M. (2016, November 21). *Variational Graph Auto-Encoders*. arXiv: 1611.07308 [stat].
<https://doi.org/10.48550/arXiv.1611.07308>
- Govaert, G., & Nadif, M. (2005). An EM algorithm for the block mixture model. *IEEE Transactions on Pattern Analysis and Machine Intelligence*, 27(4), 643–647.
<https://doi.org/10.1109/TPAMI.2005.69>
- Daudin, J.-J., Picard, F., & Robin, S. (2008). A mixture model for random graphs. *Statistics and Computing*, 18(2), 173–183.
<https://doi.org/10.1007/s11222-007-9046-7>

References III

- Chabert-Liddell, S.-C., Barbillon, P., & Donnet, S. (2024). Learning common structures in a collection of networks. An application to food webs. *The Annals of Applied Statistics*, *18*(2), 1213–1235. <https://doi.org/10.1214/23-AOAS1831>
- Biernacki, C., Celeux, G., & Govaert, G. (2000). Assessing a mixture model for clustering with the integrated completed likelihood. *IEEE Transactions on Pattern Analysis and Machine Intelligence*, *22*(7), 719–725. <https://doi.org/10.1109/34.865189>
- Pu, D., Fan, X., & Fang, K. (2025). Tree-Enhanced Latent Space Models for Two-Mode Networks. *Journal of Computational and Graphical Statistics*, *0*(0), 1–9. <https://doi.org/10.1080/10618600.2025.2527295>
- Wilms, I., & Bien, J. (2022). Tree-based Node Aggregation in Sparse Graphical Models. *Journal of Machine Learning Research*, *23*(243), 1–36. Retrieved October 14, 2025, from <http://jmlr.org/papers/v23/21-0105.html>

Clustering algorithm

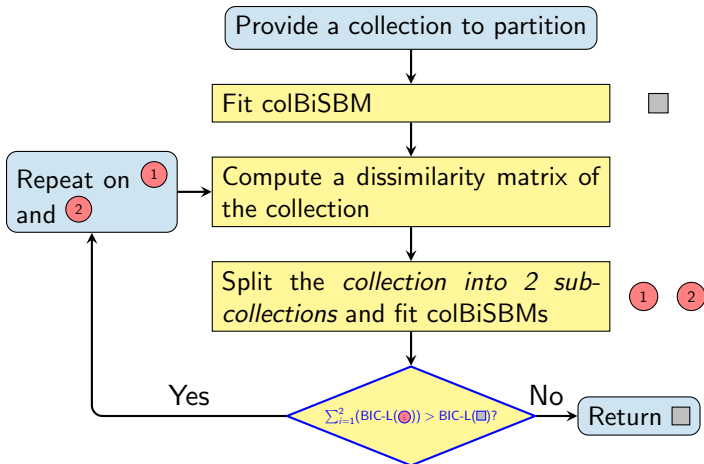

$$D_{\mathcal{M}}(m, m') = \sum_{q=1}^{Q_1} \sum_{r=1}^{Q_2} \max(\tilde{\pi}_q^m, \tilde{\pi}_q^{m'}) \left(\tilde{\alpha}_{qr}^m - \tilde{\alpha}_{qr}^{m'} \right)^2 \max(\tilde{\rho}_r^m, \tilde{\rho}_r^{m'})$$

Developed formula of variational EM

$$\begin{aligned}
 \ell(\mathbf{Y}; \theta) \geq & \sum_{m=1}^M \left(\sum_{i=1}^{n_1^m} \sum_{j=1}^{n_2^m} \sum_{q \in \mathcal{Q}_{1,m}} \sum_{r \in \mathcal{Q}_{2,m}} \tau_{i,q}^{1,m} \tau_{j,r}^{2,m} \log f(Y_{ij}^m; \alpha_{qr}) \right. \\
 & + \sum_{i=1}^{n_1^m} \sum_{q \in \mathcal{Q}_{1,m}} \tau_{i,q}^{1,m} \log \pi_q^m + \sum_{j=1}^{n_2^m} \sum_{r \in \mathcal{Q}_{2,m}} \tau_{j,r}^{2,m} \log \rho_r^m \\
 & \left. - \sum_{i=1}^{n_1} \tau_{i,q}^{1,m} \log \tau_{i,q}^{1,m} - \sum_{j=1}^{n_2} \tau_{j,r}^{2,m} \log \tau_{j,r}^{2,m} \right) =: \mathcal{J}(\tau; \theta),
 \end{aligned}$$

Variational approximation

$$\tau_{iq}^{1,m} = \mathcal{R}_{Y^m, \tau}^1(Z_{iq}^m = 1) \text{ and } \tau_{jr}^{2,m} = \mathcal{R}_{Y^m, \tau}^2(W_{jr}^m = 1)$$

Variational Expectation Step

$$\hat{\tau}^{(t+1)} = \arg \max_{\tau} \mathcal{J}(\tau, \hat{\theta}^{(t)}) \Leftrightarrow \arg \min_{\tau \in \mathcal{T}} \mathbf{KL}[\mathcal{R}_{\mathbf{Y}, \tau}, \mathbb{P}(\cdot | \mathbf{Y})]$$

$$\begin{cases} \hat{\tau}_{iq}^{1,m} \propto \hat{\pi}_q^{m(t)} \prod_{j=1}^{n_2^m} \prod_{r \in \mathcal{Q}_2^m} f(Y_{ij}^m; \hat{\alpha}_{qr}^{(t)}) \hat{\tau}_{jr}^{2,m(t+1)} & \forall i = 1, \dots, n_1^m, q \in \mathcal{Q}_1^m \\ \hat{\tau}_{jr}^{2,m} \propto \hat{\rho}_r^{m(t)} \prod_{i=1}^{n_1^m} \prod_{q \in \mathcal{Q}_1^m} f(Y_{ij}^m; \hat{\alpha}_{qr}^{(t)}) \hat{\tau}_{iq}^{1,m(t+1)} & \forall j = 1, \dots, n_2^m, r \in \mathcal{Q}_2^m \end{cases}$$

²Initialization of $\hat{\tau}$ with a *spectral clustering* on the networks.

Maximization Step

$$\hat{\theta}^{(t+1)} = \arg \max_{\theta} \mathcal{J}(\hat{\tau}^{(t+1)}, \theta)$$

Connectivity parameters

$$\hat{\alpha}_{qr} = \frac{\sum_{m=1}^M \sum_{i=1}^{n_1^m} \sum_{j=1}^{n_2^m} \tau_{iq}^{1,m} \tau_{jr}^{2,m} Y_{ij}^m}{\sum_{m=1}^M \sum_{i=1}^{n_1^m} \sum_{j=1}^{n_2^m} \tau_{iq}^{1,m} \tau_{jr}^{2,m}}$$

Proportions for *iid*

$$\hat{\pi}_q = \frac{\sum_{m=1}^M \sum_{i=1}^{n_1^m} \tau_{iq}^{1,m}}{\sum_{m=1}^M n_1^m}$$

$$\hat{\rho}_r = \frac{\sum_{m=1}^M \sum_{j=1}^{n_2^m} \tau_{jr}^{2,m}}{\sum_{m=1}^M n_2^m}$$

Maximization Step

$$\hat{\theta}^{(t+1)} = \arg \max_{\theta} \mathcal{J}(\hat{\tau}^{(t+1)}, \theta)$$

Connectivity parameters

$$\hat{\alpha}_{qr} = \frac{\sum_{m=1}^M \sum_{i=1}^{n_1^m} \sum_{j=1}^{n_2^m} \tau_{iq}^{1,m} \tau_{jr}^{2,m} Y_{ij}^m}{\sum_{m=1}^M \sum_{i=1}^{n_1^m} \sum_{j=1}^{n_2^m} \tau_{iq}^{1,m} \tau_{jr}^{2,m}}$$

Proportions for $\pi\rho$

$$\hat{\pi}^m_q = \frac{\sum_{i=1}^{n_1^m} \tau_{iq}^{1,m}}{n_1^m}$$

$$\hat{\rho}^m_r = \frac{\sum_{j=1}^{n_2^m} \tau_{jr}^{2,m}}{n_2^m}$$

Why does VE minimizes KL ?

$$\ell_c(\mathbf{Y}, \mathbf{Z}, \mathbf{W}; \theta) = \log \mathbb{P}(\mathbf{Z}, \mathbf{W} | \mathbf{Y}; \theta) + \ell(\mathbf{Y}; \theta)$$

$$\Leftrightarrow \ell(\mathbf{Y}; \theta) = \ell_c(\mathbf{Y}, \mathbf{Z}, \mathbf{W}; \theta) - \log \mathbb{P}(\mathbf{Z}, \mathbf{W} | \mathbf{Y}; \theta)$$

$$\Leftrightarrow \mathbb{E}_{\mathcal{R}_{\mathbf{Y}, \tau}}[\ell(\mathbf{Y}; \theta)] = \mathbb{E}_{\mathcal{R}_{\mathbf{Y}, \tau}}[\ell_c(\mathbf{Y}, \mathbf{Z}, \mathbf{W}; \theta)] - \mathbb{E}_{\mathcal{R}_{\mathbf{Y}, \tau}}[\log \mathbb{P}(\mathbf{Z}, \mathbf{W} | \mathbf{Y}; \theta)]$$

$$\Leftrightarrow \ell(\mathbf{Y}; \theta) = \mathbb{E}_{\mathcal{R}_{\mathbf{Y}, \tau}}[\ell_c(\mathbf{Y}, \mathbf{Z}, \mathbf{W}; \theta)] - \mathbb{E}_{\mathcal{R}_{\mathbf{Y}, \tau}}[\log \mathbb{P}(\mathbf{Z}, \mathbf{W} | \mathbf{Y}; \theta)]$$

$$\begin{aligned} \text{But } \mathbf{KL}[\mathcal{R}_{\mathbf{Y}, \tau}, \log \mathbb{P}(\mathbf{Z}, \mathbf{W} | \mathbf{Y}; \theta)] &= -\mathbb{E}_{\mathcal{R}_{\mathbf{Y}, \tau}} \left[\log \frac{\mathbb{P}(\mathbf{Z}, \mathbf{W} | \mathbf{Y}; \theta)}{\mathcal{R}_{\mathbf{Y}, \tau}} \right] \\ &= -\mathbb{E}_{\mathcal{R}_{\mathbf{Y}, \tau}} [\log \mathbb{P}(\mathbf{Z}, \mathbf{W} | \mathbf{Y}; \theta)] + \underbrace{\mathbb{E}_{\mathcal{R}_{\mathbf{Y}, \tau}} [\log \mathcal{R}_{\mathbf{Y}, \tau}]}_{-\mathcal{H}(\mathcal{R}_{\mathbf{Y}, \tau})} \end{aligned}$$

$$\Leftrightarrow \mathbf{KL}[\mathcal{R}_{\mathbf{Y}, \tau}, \log \mathbb{P}(\mathbf{Z}, \mathbf{W} | \mathbf{Y}; \theta)] + \mathcal{H}(\mathcal{R}_{\mathbf{Y}, \tau}) = -\mathbb{E}_{\mathcal{R}_{\mathbf{Y}, \tau}} [\log \mathbb{P}(\mathbf{Z}, \mathbf{W} | \mathbf{Y}; \theta)]$$

Thus $\ell(\mathbf{Y}; \theta) - \mathbf{KL}[\mathcal{R}_{\mathbf{Y}, \tau}, \log \mathbb{P}(\mathbf{Z}, \mathbf{W} | \mathbf{Y}; \theta)] = \mathcal{J}(\tau; \theta)$ \square

On the BIC-L

$$\text{ICL}(\hat{\theta}) = \mathbb{E}_{\mathbf{Z}, \mathbf{W} | \mathbf{Y}}[\ell_c(\mathbf{Y}, \mathbf{Z}, \mathbf{W}; \hat{\theta})] - \frac{1}{2} \text{pen}(\dots)$$

$$\mathbb{E}_{\mathbf{Z}, \mathbf{W} | \mathbf{Y}}[\ell_c(\mathbf{Y}, \mathbf{Z}, \mathbf{W}; \hat{\theta})] = \log p(\mathbf{Y}; \hat{\theta}) - \mathcal{H}(p(\mathbf{Z}, \mathbf{W} | \mathbf{Y}))$$

$$\text{And thus, } \text{ICL}(\hat{\theta}) = \log p(\mathbf{Y}; \hat{\theta}) - \mathcal{H}(p(\mathbf{Z}, \mathbf{W} | \mathbf{Y})) - \frac{1}{2} \text{pen}(\dots)$$

$\mathbf{Z}, \mathbf{W} | \mathbf{Y}$ intractable, use the *variational approximation* $\mathcal{R}_{\mathbf{Y}, \hat{\tau}}$ and don't penalize the entropy we derive the BIC-Like:

$$\text{BIC-L}(\hat{\theta}, \hat{\tau}) = \mathbb{E}_{\mathcal{R}_{\mathbf{Y}, \hat{\tau}}}[\ell_c(\mathbf{Y}, \mathbf{Z}, \mathbf{W}; \hat{\theta}^{\text{var}})] + \mathcal{H}(\mathcal{R}_{\mathbf{Y}, \hat{\tau}}) - \frac{1}{2} \text{pen}(\dots)$$

Biernacki et al., 2000; Daudin et al., 2008; Chabert-Liddell et al., 2024

Practical problems of choosing Q_1, Q_2

Exploration problems

- Sensitivity to initializations.
- Exploration of a 2D grid is costly.

Practical problems of choosing Q_1, Q_2

Exploration problems

- Sensitivity to initializations. → **Spectral clustering** and **split & merge** approach
- Exploration of a 2D grid is costly.

Practical problems of choosing Q_1, Q_2

Exploration problems

- Sensitivity to initializations. → **Spectral clustering** and **split & merge** approach
- Exploration of a 2D grid is costly. → **Greedy approach** and **sliding window**

Choice of (Q_1, Q_2) - Greedy approach

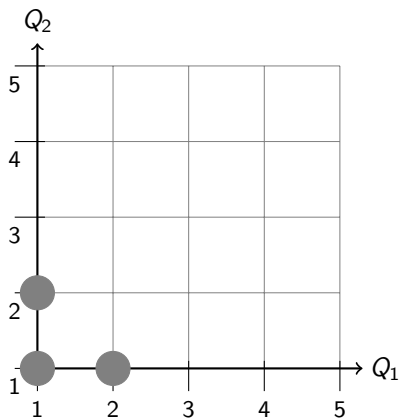

● Initial model :
●

Choice of (Q_1, Q_2) - Greedy approach

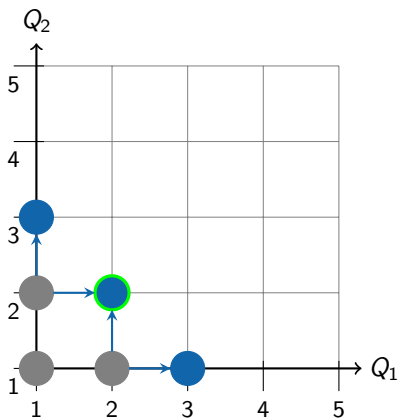

- Initial model :
●
- Model after *split* :
●
- Model maximizing the criterion :
○

Choice of (Q_1, Q_2) - Greedy approach

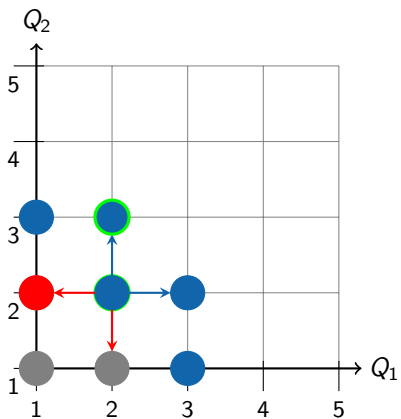

- Initial model :
●
- Model after *split* :
●
- Model maximizing the criterion :
○
- Model after *merge* :
●

Choice of (Q_1, Q_2) - Sliding window

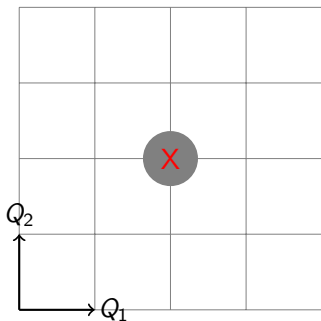

Figure 10: Sliding window

Choice of (Q_1, Q_2) - Sliding window

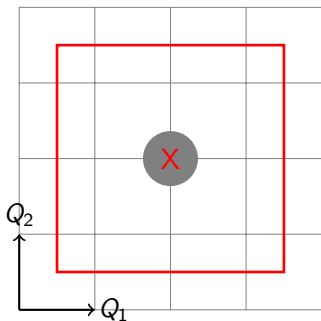

Figure 10: Sliding window

Choice of (Q_1, Q_2) - Sliding window

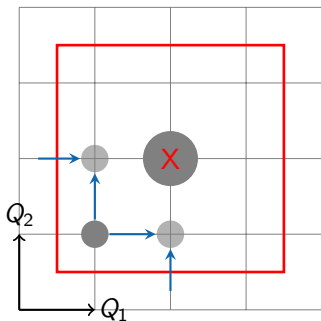

Figure 10: Sliding window

Initialization of the model if necessary

Choice of (Q_1, Q_2) - Sliding window

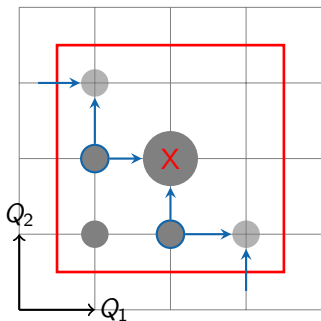

Figure 10: Sliding window

Choice of (Q_1, Q_2) - Sliding window

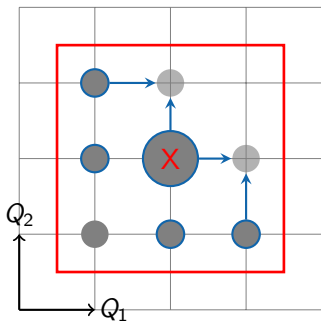

Figure 10: Sliding window

Choice of (Q_1, Q_2) - Sliding window

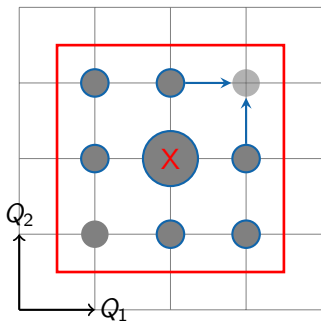

Figure 10: Sliding window

Choice of (Q_1, Q_2) - Sliding window

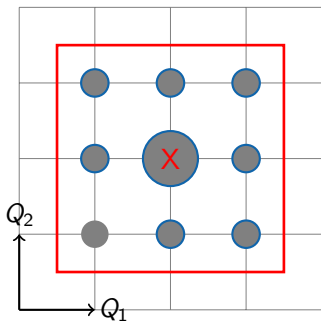

Figure 10: Sliding window

Choice of (Q_1, Q_2) - Sliding window

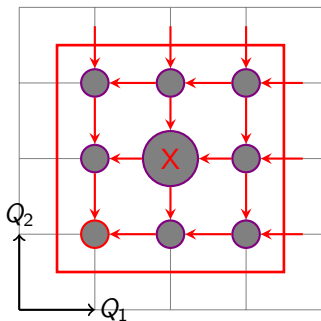

Figure 10: Sliding window

Choice of (Q_1, Q_2) - Sliding window

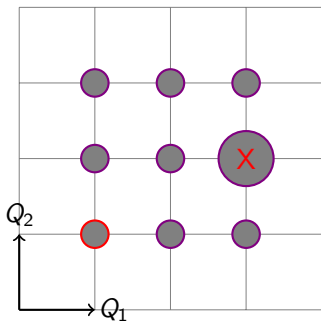

Figure 10: Sliding window

Localization of the new mode

Choice of (Q_1, Q_2) - Sliding window

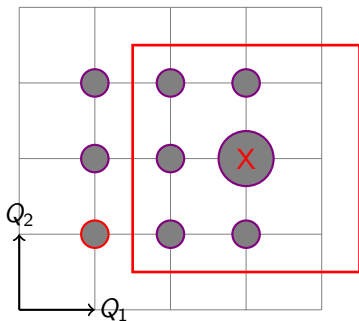

Figure 10: Sliding window

Move to the new mode then iterate



Figure 12: Map of the four cities

Appendices references I

- Biernacki, C., Celeux, G., & Govaert, G. (2000). Assessing a mixture model for clustering with the integrated completed likelihood. *IEEE Transactions on Pattern Analysis and Machine Intelligence*, 22(7), 719–725. <https://doi.org/10.1109/34.865189>
- Daudin, J.-J., Picard, F., & Robin, S. (2008). A mixture model for random graphs. *Statistics and Computing*, 18(2), 173–183. <https://doi.org/10.1007/s11222-007-9046-7>
- Chabert-Liddell, S.-C., Barbillion, P., & Donnet, S. (2024). Learning common structures in a collection of networks. An application to food webs. *The Annals of Applied Statistics*, 18(2), 1213–1235. <https://doi.org/10.1214/23-AOAS1831>